

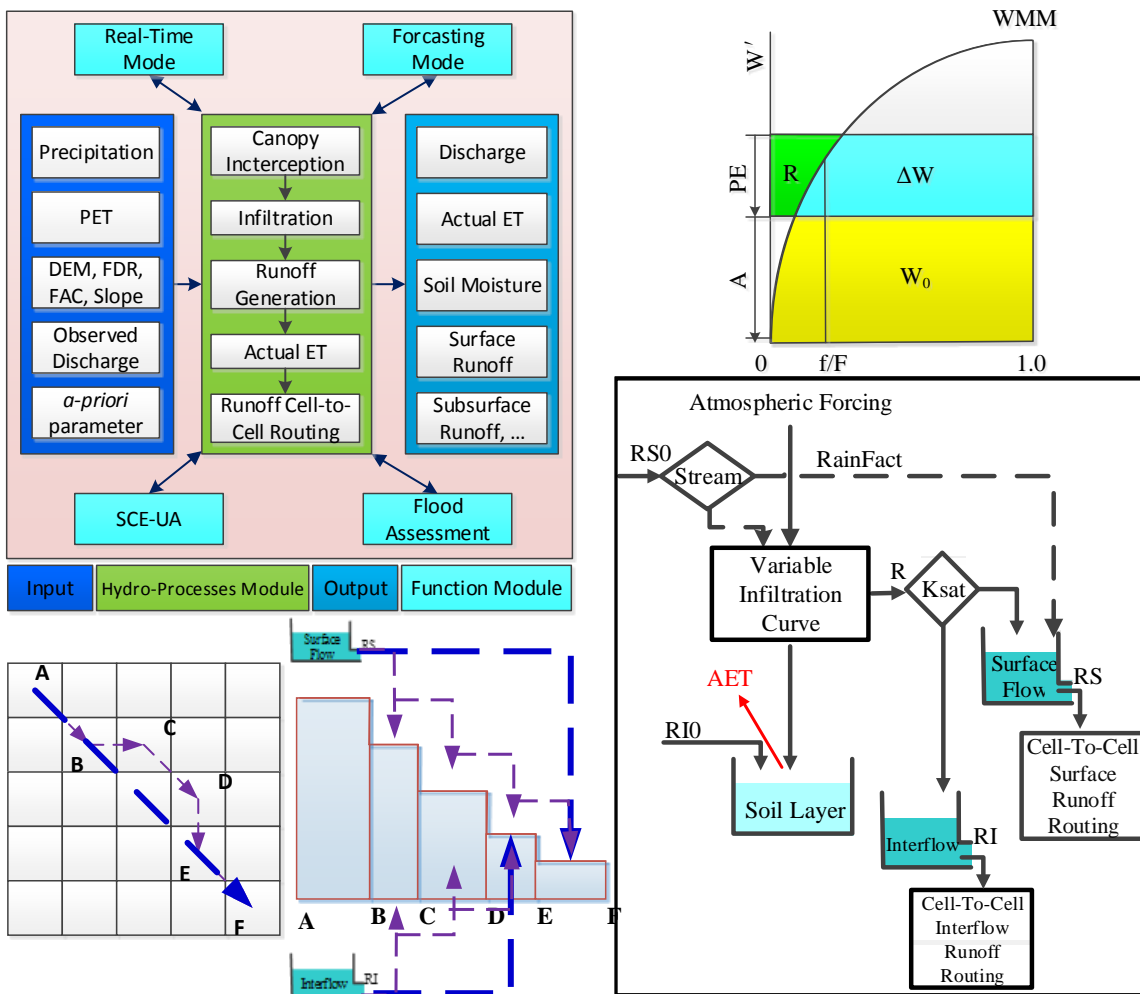

NASA University of Oklahoma (OU) HyDROS Lab (<http://hydro.ou.edu>)

CREST
Coupled **R**outing and **E**xcess **S**Torage
 User Manual
 © CREST Version 2.1-Fortran



By Dr. Xianwu Xue, Dr. Yang Hong and Dr. Ke Zhang

Cover: **CREST**—Coupled Routing and Excess Storage User Manual Version 2.1

Brief Version History:

02/02/2011 Model was updated from CREST v1.6c to Modular Designed v2.0 with
embedded SCE-UA (Developed by Dr. Xianwu Xue and Dr. Yang Hong)

01/11/2014 Model was updated to v2.0.3

10/31/2014 Model was updated to v2.1

Table of Contents

CREST	1
TABLE OF CONTENTS	1
1 INTRODUCTION	1
2 NEW FEATURES OF CREST IN DIFFERENT VERSIONS FOR ADDITIONAL READING	1
2.1 What's New in CREST v2.1	1
2.2 New features in CREST v2.0 (also inherited by the CREST v2.1)	1
3 COMPILATIONS	13
3.1 Compiling on Linux Systems.....	13
3.2 Compiling on Window Systems.....	13
4 PROJECT FILE	15
4.1 Model Area.....	15
4.2 Model Run Time Information	16
4.3 Model Run Style	17
4.4 Routing Type.....	17
4.5 Model Directory.....	19
4.6 OutPix Information	20
4.7 Outlet Information	21
4.8 Grid Outputs.....	21
4.9 Date Outputs	23
4.10 Number of Lakes.....	23
5 INPUTS & OUTPUTS	25
5.1 Basics Folder.....	25
5.2 Params Folder	32

5.3 State Folder	35
5.4 ICS Folder	35
5.5 OBS Folder	37
5.6 Calibs Folder	37
5.7 Rains Folder	41
5.8 PETs Folder.....	41
5.9 Results Folder	41
6 RUN STYLES	43
6.1 Simulation	43
6.2 Automatic Calibration using SCE-UA.....	46
6.3 Simulation in real time mode.....	49
6.4 Return Period mode	50
7 IMPLEMENTATION OF THE CREST MODEL FOR OTHER BASINS.....	53
8 CONTACT	55
9 SELECTED CREST MODEL RELATED REFERENCES.....	55
10 APPENDIX A LOOK-UP TABLES	57

1 Introduction

The **C**oupled **R**outing and **E**xcess **S**Torage (CREST) distributed hydrological model is a hybrid modeling strategy that was jointly developed by the University of Oklahoma (<http://hydro.ou.edu>) and NASA SERVIR Project Team (www.servir.net). The CREST model was initially designed to provide real-time regional and global hydrological prediction by simultaneously modeling over multi-basins with significantly cost-effective computational efficiency (<http://eos.ou.edu>), however it is also very applicable for small to medium size basins at very high-resolutions. CREST simulates the spatiotemporal variation of water and energy fluxes and storages on a regular grid with the grid cell resolution being user-defined, thereby enabling multi-scale applications. The scalability of CREST simulations is accomplished through sub-grid scale representation of soil moisture storage capacity (using a variable infiltration curve) and multi-scale runoff generation processes (using multi-linear reservoirs). The representation of the primary water fluxes such as infiltration and routing are physically related to the spatially variable land surface characteristics (i.e., vegetation, soil type, and topography etc.). The runoff generation process and routing scheme are coupled, thus providing more realistic interactions between lower atmospheric boundary layers, terrestrial surface, and subsurface water. The above flexible modeling features and embedded automated calibration algorithms make the CREST a powerful yet cost-effective tool for distributed hydrological modeling and implementation at global, regional, basin, and small catchment scales.

This user manual and the accompanying software package enable first-time users to test the model with a single basin example. **Section 2** provides more information on new features of different model versions but users can jump to **Section 3** for source code compilations or directly go to **Section 4-6** to learn how to implement the model with the provided basin example. Then **Section 7** will guide the user how to set up and calibrate the model in new study areas. For more guidance of CREST model implementation, please contact us or download the week-long training materials in Kenya from this link: http://hydro.ou.edu/research/crest/crest-model-training-materials/#crest_workshop.

2 New Features of CREST in different Versions for additional reading

2.1 What's New in CREST v2.1

- 1) Updated the continuous multi-linear reservoir routing option (See Figure 5-5), with the Keyword RouteType for this routing option in order to compatible with the CREST Model v2.0
- 2) Make the “CalibMask” file optional.
- 3) Improved the modeling compatibility at multiple temporal scales, ranging from minute, hour, day, month and year.
- 4) Fixed the display of digital numbers using **Star** during the simulation/ calibration on the terminal interface and also in the log file

2.2 New features in CREST v2.0 (also inherited by the CREST v2.1)

2.2.1 Main Features of CREST v2.0

- A modular design framework to accommodate research, development and system enhancements (see Fig. 2(a) in Xue et al. (2013))
- Inclusion of the optimization scheme SCEUA to enable automatic calibration of the CREST model parameters (see Fig. 2(a) in Xue et al. (2013))
- QPF Forecast Function Mode was incorporated and applied in the NASA SERVIR Africa Project (<https://www.servirglobal.net/EastAfrica/MapsData.aspx>)
- All the parameters in CREST v1.6c were classified into three types: Initial Conditions, Physical Parameters (to be derived by a-priori parameter method), and conceptual parameters (to be calibrated), some of the non-sensitive parameters were omitted (more details in user manual)
- Model implementation with options of either spatially uniform, semi-distributed, or fully distributed parameterization schemes
- A multi-site cascading calibration framework was used to calibrate the model using multi-site streamflow gauge data from upstream to downstream (Users

- should prepare the streamflow data)
- Enhancement of the computation capability using matrix manipulation
 - Project file was used to replace the original control file, and users can pass the project file to the CREST model instead of putting both the crest model executable file and the control file under the same directory path. Additionally, the statements in the project file could be in any order and more flexible
 - The Model can write out all the output variables in any given time (spatially distributed data) and in any designated location (Time series)

2.2.2 Summary of the codes:

- V1.6c Total: 2106 Lines
- V2.0.00 Total: 8841 Lines
 - Include: 5437 Lines of Main CREST
 - 3403 Lines of CREST-UA

2.2.3 Framework and Modular Design of CREST Model

Comparing to previous CREST v1.6c, the programming framework of CREST v2.0 was redesigned to better suit for distributed hydrological modeling. As shown in Figure 2-1 and Figure 2-2 (Xue et al. (2013)), CREST v2.0 includes more spatially distributed input data (including a prior parameters) and outputs more variables data.

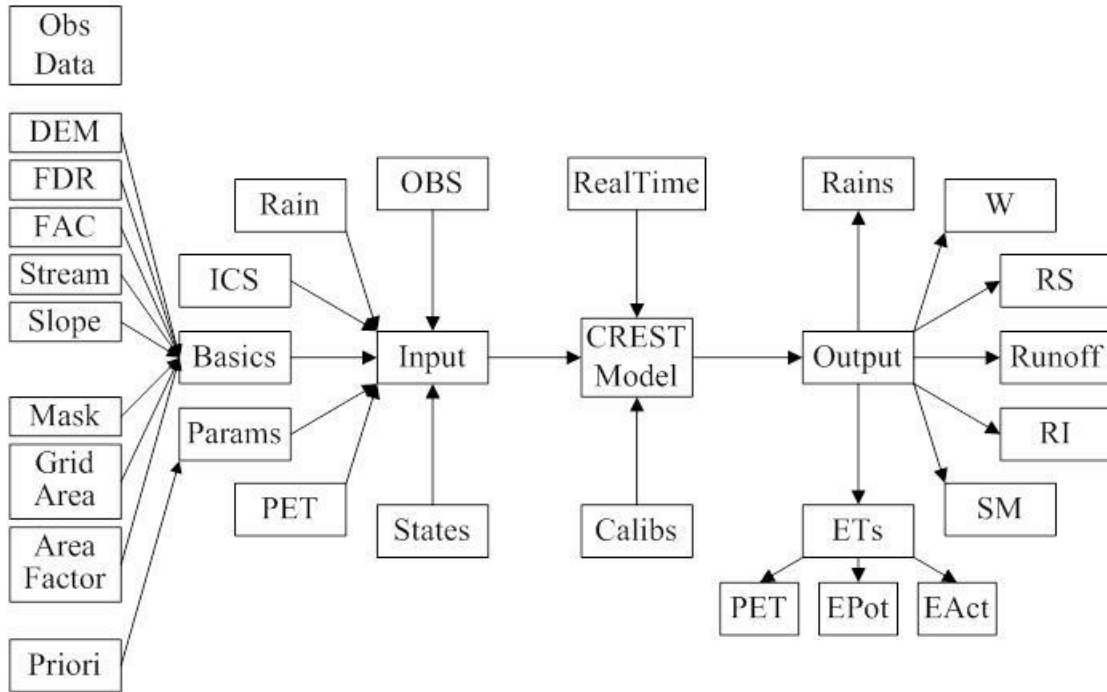

Figure 2-1 Programming Framework of CREST v2.0

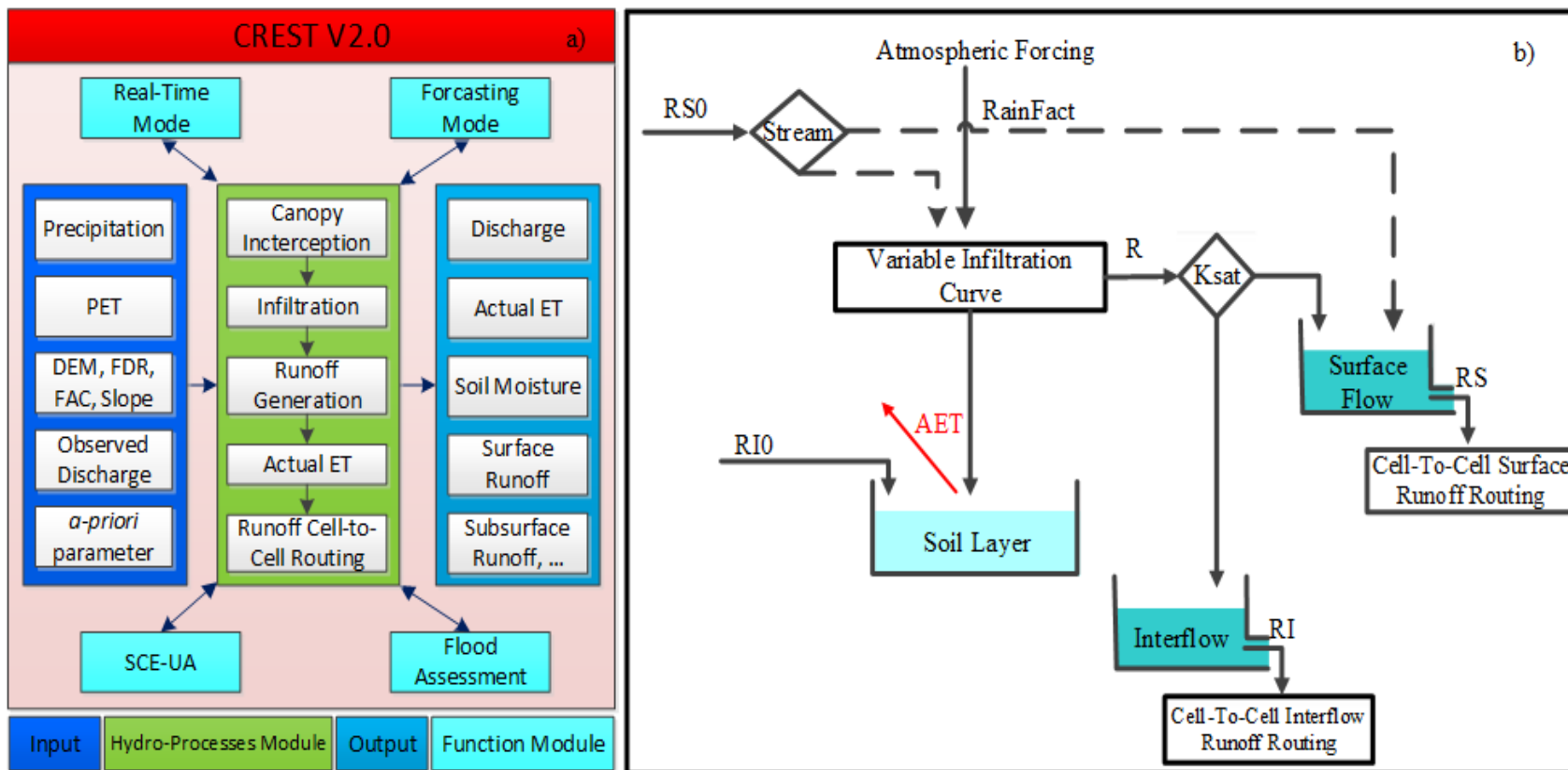

Figure 2-2 (a) The framework of the CREST model version 2.0 and (b) vertical profile of hydrological processes in a grid cell.

2.2.4 Organization of the Files and Folders

The previous version CREST v1.6c puts all data information into “**Control.txt**” (Figure 2-3); this will make the control file too big when modelers want to add other parameters or data into the CREST. Additionally, when implementation of the model becomes complex, it will contain too many files under one file folder, causing unnecessary confusion and inconvenience to users or modelers.

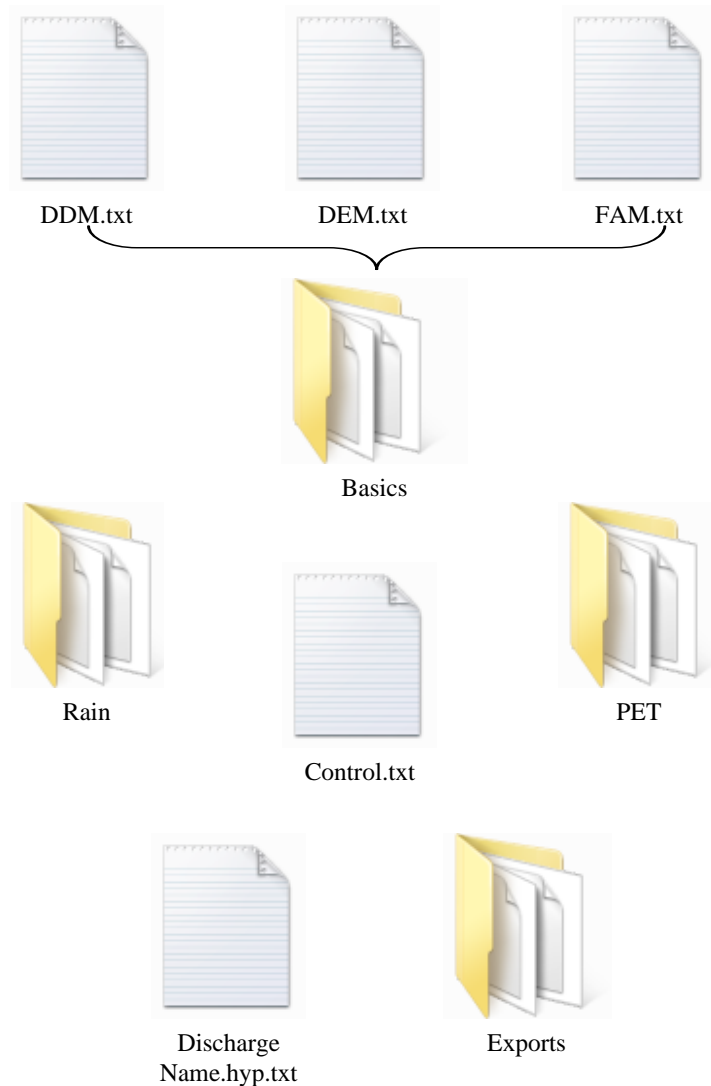

Figure 2-3 Files’ and Folders’ Organization of CREST v1.6c

In CREST v2.0, control file was divided into “ProjectName.Project”,

“Parameters.txt”, “InitialConditions.txt” and “Calibrations.txt”. Each of four files is put in standalone folders, including other related data and files. Thus the “ProjectName.Project” file only contains the model’s input information and its configuration. This will enables user to build and modify these files easily. Figure 2-4 shows all the folders defined in CREST v2.0 based on their functionality. More detailed information of these folders will be discussed in following sections.



Figure 2-4 Files’ and Folders’ Organization of CREST v2.0

2.2.5 Comparison with CREST v1.6c

Compare the simulation

	1	2	3	4	5	6	Ave
v1.6c	8.019	4.415	4.461	4.368	4.462	4.43	5.632
v2.0.00	5.039	2.917	2.886	2.885	3.042	3.369	3.614

Compare the calibration

	Iteration	Elapsed Time	NSCE
v1.6c	15795	8h 25min	0.990432
v2.0.00	3000	1h 46min	0.999989
Cascading (2Region)	3000	3h 35min	0.999548

NSCE	0.999988574	NSCE	0.999998757	NSCE	0.999548
Bias (%)	-0.00926862	Bias (%)	-0.004382075	Bias (%)	0.371125
CC	0.99999502	CC	0.999999408	CC	0.999816

One Region

Two Regions
(Upstream point (left), Outlet (right))

Figure 2-5 Comparison of CREST v1.6c and v2.0 in the running efficiency

2.2.6 Pre-Process of CREST v2.0

Basics Data Inputs:

Support More File Formats:

ASC, TXT, DBIF, BIFFIT, TRMMRT, TRMMV6, TRMMV7, NMQBIN, ASBIMO, BIBIMO

Flow Direction Map

Support Both CNT flow direction codes and ArcGIS flow direction codes

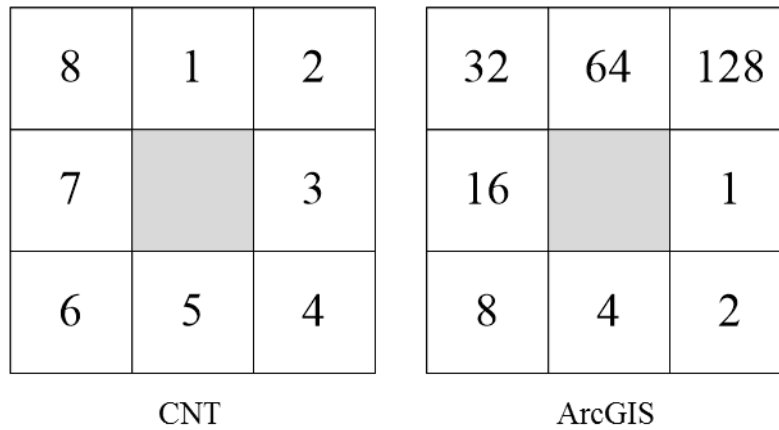

Figure 2-6 Flow Direction Coding

Stream Map

Omit TH parameter

Slope Map

Omit GM Parameter

Make the mask, GridArea and AreaFactor maps to optional

2.2.7 Parameters Classification

Table 2-1 Parameters in CREST v1.6 and v2.0

Module	Symbol (v2.0)	Symbol (v1.6c)	Description
Initial Condition	W0	iWU	Initial Value of Soil Moisture
	SS0	iSO	Initial value of Overland Reservoir
	SI0	iSI	Initial value of Interflow reservoir
Physical Parameters	Ksat	pFc	the Soil saturate hydraulic conductivity
	RainFact	Rain	the multiplier on the precipitation field
	WM	pWm	The Mean Water Capacity
	B	B	the exponent of the variable infiltration curve
	IM	pIM/100	Impervious area ratio
	KE	pKE	The factor to convert the PET to local actual
Conceptual Parameters	coeM	coeM	overland runoff velocity coefficient
	expM	expM	overland flow speed exponent
	coeR	River	multiplier used to convert overland flow

	coeS	Under	speed to channel flow speed multiplier used to convert overland flow speed to interflow flow speed
	KS	LeakO	Overland reservoir Discharge Parameter
	KI	LeakI	Interflow Reservoir Discharge Parameter
Adjustment Parameters	(Omitted)/TH	TH	Threshold to determine which cells are river cells
	(Omitted)/GM	GM	downstream cell is higher than the upstream downstream cell is a nodata/outside region cell
	AreaFact	AreaC	multiplier that modifies the area of grid cells

2.2.8 Input Data

Use ProjectName.Project as the main control file for CREST v2.0, Use “#” in the beginning of the line as the comments, all of the inputs in the project file can be in any order.

In the CREST v2.0, there are two files to control the initial conditions and parameters respectively, they can input both uniform value and/or distributed values.

For the observed streamflow data, .csv format same as Excel are used to convenient to be prepared by Excel.

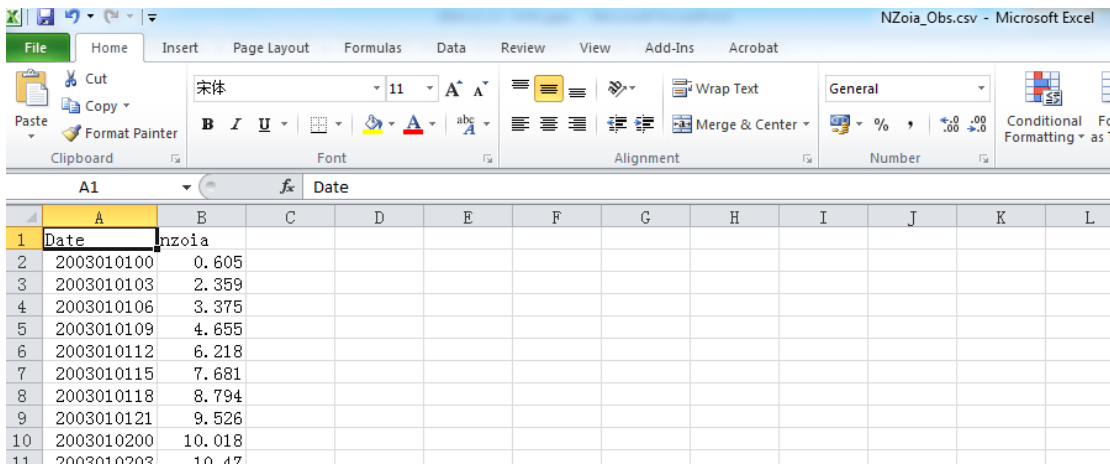

Figure 2-7 Example of the observed streamflow file

For the Precipitation and Potential Evapotranspiration data, the users can use any formats and CREST v2.0 can clip the area automatically when the data area is different with the defined research area in project file. So ClipRe parameter in CREST v1.6c is

omitted.

2.2.9 Mode Structure

Divide the processes into subroutines to make the codes easy to understand and modification

- a) Canopy Interception
- b) Potential Evapotranspiration
- c) Runoff Generation
- d) Actual Evapotranspiration
- e) Runoff Route

Encapsulate the variables into different modules and its types, and add “g_” as the prefix to strength the code readable

2.2.10 Output Data

- Output the Outlet’s data
- Output the all the inner points’ data including its upstream area’s average Rain and PET
- Output the specified state variables’ data
- Output the specified time's data
- Automatically compute the NSCE, Bias and CC when outlet and inner pints having observation data
- The output data files use their data type as prefix to make the user know them easily

2.2.11 Output & Post-Process

CSV format is used for the outlet and any location output results.

2.2.12 Calibration

Optimize the distributed parameters using SCE-UA and Matrix Manipulation

```

where (g_RegMask==g_tCalibSta(g_RegNum)%Value)

  g_tParamsAdj_Cali%RainFact = g_tCalibSta(g_RegNum)%x(1)
  g_tParamsAdj_Cali%Ksat     = g_tCalibSta(g_RegNum)%x(2)
  g_tParamsAdj_Cali%WM       = g_tCalibSta(g_RegNum)%x(3)
  g_tParamsAdj_Cali%B        = g_tCalibSta(g_RegNum)%x(4)
  g_tParamsAdj_Cali%IM       = g_tCalibSta(g_RegNum)%x(5)
  g_tParamsAdj_Cali%KE       = g_tCalibSta(g_RegNum)%x(6)
  g_tParamsAdj_Cali%coeM     = g_tCalibSta(g_RegNum)%x(7)

  g_tParamsAdj_Cali%expM     = g_tCalibSta(g_RegNum)%x(8)
  g_tParamsAdj_Cali%coeR     = g_tCalibSta(g_RegNum)%x(9)
  g_tParamsAdj_Cali%coeS     = g_tCalibSta(g_RegNum)%x(10)
  g_tParamsAdj_Cali%KS       = g_tCalibSta(g_RegNum)%x(11)
  g_tParamsAdj_Cali%KI       = g_tCalibSta(g_RegNum)%x(12)
  g_tParamsAdj_Cali%TH       = g_tCalibSta(g_RegNum)%x(13)
  g_tParamsAdj_Cali%GM       = g_tCalibSta(g_RegNum)%x(14)
  g_tParamsAdj_Cali%AreaFact = g_tCalibSta(g_RegNum)%x(15)

end where

```

Figure 2-8 Matrix Manipulation

Using cascading strategy calibrate the model automatically using different regions with different parameters' dataset based on the calibration stations' region number

2.2.13 Fix some bugs

- Take TH and FAC for example
- FAC has two means:
 1. Number of the upstream grids
 2. Upstream basin's area

From codes, TH is the area, not the number, so should sum the upstream grids area

3 Compilations

This CREST model version is written in FORTRAN, and will run under most operating systems. It has been successfully implemented on Pentium & PC based systems (Microsoft Windows and Linux).

It is not necessary to modify the source code of CREST in order to change settings or switch to other basins. In CREST v1.6, the control file with a default name of “control.txt” and basic grids dictate the necessary settings for running the model. However, CREST V2.1 control file uses “ProjectName.Project” instead of the “control.txt”. Users are recommended to name the control file “ProjectName.project” as specific projects if you have multiple projects using the model in same file system.

3.1 Compiling on Linux Systems

The Linux/Unix operating systems are case sensitive. So when you compile CREST model, you must pay attention to the name and extension of the default file.

3.1.1 Using “ifort” compiler

Compiling CREST is easy with FORTRAN compiler. The source code of CREST model is contained in a single file for ease of use. As such, in order to compile CREST using ifort all you need to do is to type a simple command line "**ifort crest.for -o crest.lx**". This will compile the CREST FORTRAN source code file into an executable named "**crest.lx**". The Intel FORTRAN compiler has many other command line arguments to enable additional optimizations and other features. If you want a full list and description of how to use **ifort**, please consult the Intel FORTRAN compiler user manual.

3.2 Compiling on Window Systems

3.2.1 Using “Compaq Visual FORTRAN” (CVF) compiler

Compiling CREST is also very easy using CVF on Windows platforms, you can just open the “**crest.for**” by CVF, and then compile it, and finally, “**crest.exe**” will be created.

If you want a full list and description of how to use CVF, please consult the Compaq Visual FORTRAN compiler user manual.

4 Project File

The file “ProjectName.Project” contains the information about Model Area, Run Time Information, Configuration Directory, Run Style, Outputs Information for Specified Pixels and Outlet, Outputs States and Outputs Date, and it also contains file assignments and their formats (One line for each assignment or information).

The “ProjectName” is the name of the project, when run CREST v2.1 on Linux/Unix operating system, the extension of project file should write as “Project”, not “project” or others.

Note:

The statement in the project file can be listed in any order, but the keywords should not be changed. The format of the statement is:

Keyword = Value

The statement appearing on the same line should be space- or tab-separated.

Comment lines must have a pound sign, #, in the first column.

Comment for the statement in the line must be placed after **Value** and be sure to leave at least one space or tab between the **Value** and the comments.

Keyword is not case sensitive.

4.1 Model Area

```

5 #####
6 # MODEL AREA
7 #####
8 NCols           =      197           # Number of columns
9 NRows           =      167           # Number of rows
10 XLLCorner       =      33.94999
11 YLLCorner       =      -0.1083333
12 CellSize        =      0.008333334
13 NoData_value    =      -9999.
14 #####

```

Figure 4-1 Sample Model Area in “ProjectName.Project”

NCols: Number of cell columns;
 NRows: Number of cell rows.
 XLLCorner : X coordinate of the origin (by lower left corner of the cell).
 YLLCorner : Y coordinate of the origin (by lower left corner of the cell).
 CellSize: Cell Size.
 NoData_Value: The input values to be No Data in the input/output map file.

4.2 Model Run Time Information

```

14 #####:
15 # MODEL Run Time Information
16 #  y(year);m(month);d(day);h(hour);u(minute);s(second)
17 #####:
18 TimeMark      =      h
19 TimeStep      =      3
20 StartDate    =      2003010100
21 LoadState     =      no
22 WarmupDate   =      2003010100
23 EndDate      =      2003011000
24 SaveState    =      no
25 #####:
  
```

Figure 4-2 Sample Model Run Time Information in “ProjectName.Project”

TimeMark: The unit of time step. The possible units are “**y**” (year), “**m**” (month), “**d**” (day), “**h**” (hour), “**u**” (minute), “**s**” (second).

TimeStep: Time Step.

StartDate: Start date of the simulation, its format is defined as “yyyymmddhhuuss”, the length is up to the time step unit, for example, “yyyy” when time step unit is “y”; “yyyymmddhhuuss” when time step unit is “s”

LoadState: The mark for reading the state file. “**yes**” means user want to run the model by state files as initial value, “no” means the initial values are read determined by initial condition file.

WarmupDate: Warm up date for the simulation, its format is defined the same as

“StartDate”.

EndDate: End date for the simulation, , its format is defined the same as “StartDate”.

SaveState: The mark for saving the state file. “yes” means user want to save the state files when finished running the model, “no” means user does not want to save the state files..

4.3 Model Run Style

```

25 #####
26 # MODEL Run Style
27 #####
28 RunStyle          =      simu      # simu, cali_SCEUA, RealTime, repe
29 #####
    
```

Figure 4-3 Sample Model Run Style in “ProjectName.Project”

The run style “simu” means simulation; other possible run styles are “cali_SCEUA” (automatic calibration using SCE-UA method), “RealTime” (on line mode), and “repe” (return period) modes.

4.4 Routing Type

```

#####
RunStyle          =      cali_SCEUA  # simu, cali_SCEUA, RealTime, repe
#####
#RoutingType      =      CLR        # JLR (default), CLR
#####
# MODEL Directory
    
```

Figure 4-4 Sample Routing Type in “ProjectName.Project”

The routing component in CREST is based on a two-layer scheme describing overland runoff and interflow from one cell to the next one downstream, with consideration of open channel flow (Wang et al., 2011). In other words, the runoff in Cell A from interflow, overland flow and channel flow contribute to cells downstream D and F. We called this method as Jumped Linear Routing (Hereafter: JLR). JLR method provides a very efficient way for cell-by-cell routing. However, in some application, if the Grid Cell is very large and the time scale is very small, JLR will cause

underestimates of the streamflow. So we developed another method to solve this problem: Continuous Linear Routing (Hereafter: CLR), this method will loop all the cells the water flowed during the time step. Please note that, CLR will spend more time than JLR in most of the application.

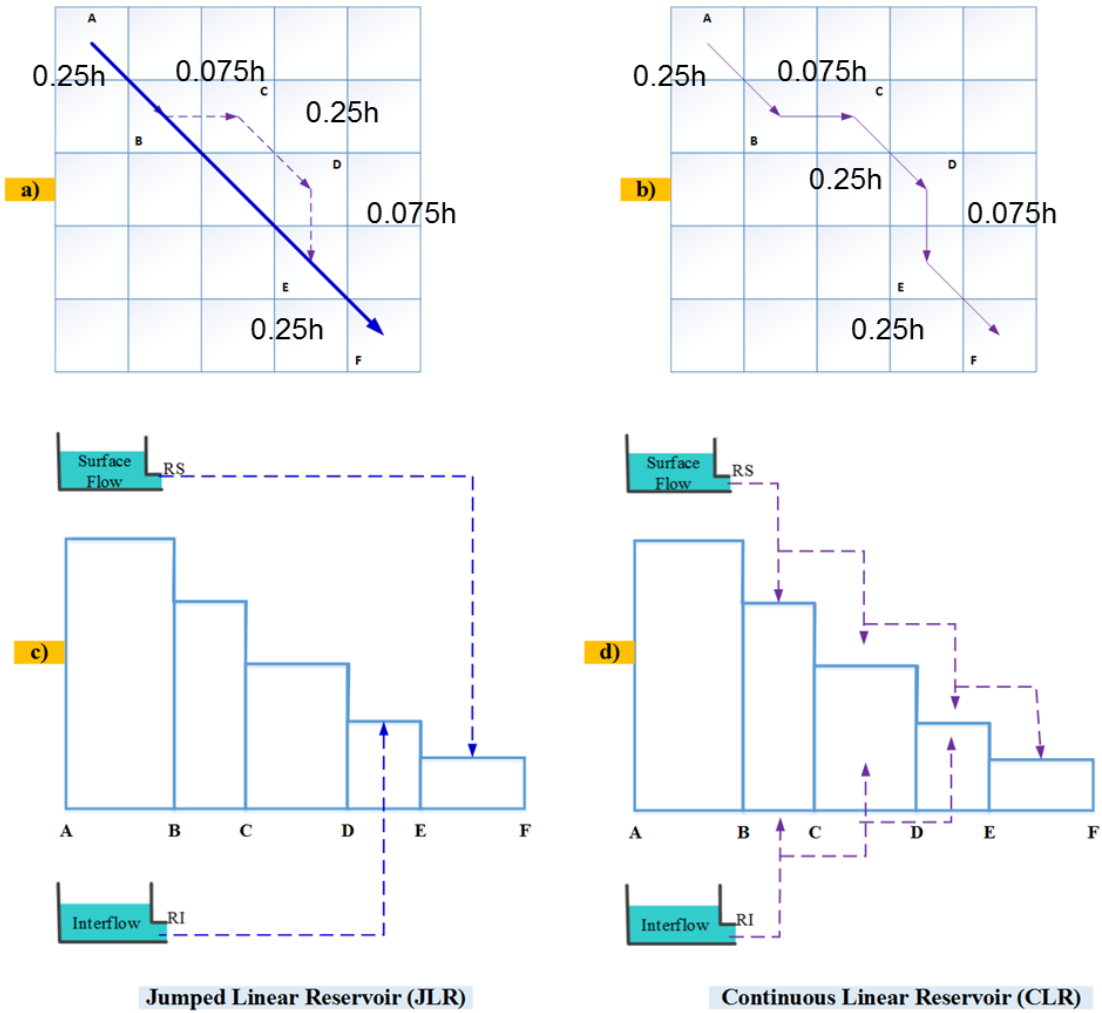

Figure 4-5 Description of the JLR and CLR in CREST v2.1

4.5 Model Directory

```

29 #####
30 # MODEL Directory
31 # Format: "ASC", "TXT", "DBIF", "BIFFIT",
32 #       "TRMMRT", "TRMMV6", "NMQBIN", "ASBIMO", "BIBIMO"
33 #####
34 BasicFormat      =      asc
35 BasicPath        =      ".\XXW_NZoia_Project\Basics\"
36 #####
37 ParamFormat      =      asc
38 ParamPath        =      ".\XXW_NZoia_Project\Params\"
39 #####
40 StateFormat      =      asc
41 StatePath        =      ".\XXW_NZoia_Project\States\"
42 #####
43 ICSFormat        =      asc
44 ICSPath          =      ".\XXW_NZoia_Project\ICS\"
45 #####
46 RainFormat       =      asc
47 RainPath         =      ".\XXW_NZoia_Project\Rains\NZoia.rain."
48 #####
49 PETFormat        =      asc
50 PETPath          =      ".\XXW_NZoia_Project\PETs\NZoia.pet."
51 #####
52 ResultFormat     =      asc
53 ResultPath       =      ".\XXW_NZoia_Project\Results\"
54 #####
55 CalibFormat      =      asc
56 CalibPath        =      ".\XXW_NZoia_Project\Calibs\"
57 #####
58 OBSFormat        =      asc
59 OBSPath          =      ".\XXW_NZoia_Project\OBS\"
60 #####

```

Figure 4-6 Sample Model Directory in “ProjectName.Project”

As shown in Figure 3-3, CREST v2.1 divides the input and output data into 9 groups, each group has a standalone folder, such as “Basics”, “Params”, “States”, “ICS”, “Rains”, “PET”, “Results”, “Calibs” and “OBS” (the name of the folder can be user-specified, but its keyword is fixed). Each folder contains some files (detailed content will be introduced in the next chapter), the format of the folder means all or most of the files in this folder will use this format. The file possible formats of CREST v2.1 are "ASC", "TXT", "DBIF", "BIFFIT", "TRMMRT", "TRMMV6", "NMQBIN", "ASBIMO" and "BIBIMO".

4.6 OutPix Information

```

60 #####:
61 # The below data are omitted, when RunStyle=cali_SCEUA
62 #####:
63 #OutPix Information
64 #####:
65 NOutPixs      =      2
66 OutPixColRow  =      no
67 OutPixName1   =      NZoia
68 OutPixLong1   =      34.08749
69 OutPixLati1   =      0.1208334
70 OutPixName2   =      XXWInnerPoint
71 OutPixLong2   =      34.537549
72 OutPixLati2   =      0.386947
73 #####:

```

Figure 4-7 Sample OutPix Information in “ProjectName.Project”

- NOutPixs:** The number of output pixels
- OutPixColRow:** **OutPixColRow** is specified if the pixel is relative to the basic grids or in latitude and longitude. A value of “**yes**” means the location of the pixels is a column and row, a value of “**no**” means the location is longitude and latitude.
- OutPixName \underline{X} :** The name of the **X**th Pixels. The value of “**X**” is up to **NOutPixs** (**X** = [1~ **NOutPixs**]).
- OutPixLong \underline{X} :** The longitude of the **X**th Pixels when OutPixColRow is assigned “**no**”.
- OutPixLati \underline{X} :** The latitude of the **X**th Pixels when OutPixColRow is assigned “**no**”.
- OutPixCol \underline{X} :** The Column of the **X**th Pixels when OutPixCol \underline{X} is assigned “**yes**”.
- OutPixRow \underline{X} :** The Row of the **X**th Pixels when OutPixCol \underline{X} is assigned “**yes**”.

4.7 Outlet Information

```

73 #####
74 #Outlet Information
75 #####
76 HasOutlet      =      yes
77 OutletColRow   =      no
78 OutletName     =      NZoia
79 OutletLong     =      34.08749
80 OutletLati     =      0.1208334
81 #####

```

Figure 4-8 Sample Outlet Information in “ProjectName.Project”

- HasOutlet: Whether have outlet or not, a value of “**yes**” means research area has an outlet, a value of “**no**” means have not.
- OutletColRow: **OutletColRow** is specified if the outlet is relative to the basic grids or in latitude and longitude. A value of “**yes**” means the outlet of the pixels is a column and row, a value of “**no**” means the outlet is longitude and latitude.
- OutletName: The name of the outlet Pixels.
- OutletLong: The longitude of the Outlet Pixels when **OutletColRow** is assigned “**no**”.
- OutletLati: The latitude of the Outlet Pixels when **OutletColRow** is assigned “**no**”.
- OutletCol: The Column of the Outlet Pixels when **OutletColRow** is assigned “**yes**”.
- OutletRow: The Row of the Outlet Pixels when **OutletColRow** is assigned “**yes**”.

4.8 Grid Outputs

Grid Outputs is the control of 2-D grid-based output, “**yes**” means output and “**no**” means do not output. The run time of the model depends on the number of outputs. A faster CREST model runtime can be achieved by reducing the number of output variables. Output format is controlled by the **ResultFormat** in section 4.4. All outputs are spatially

interpolated to the proper resolution and clipped to either the basic grids or the drainage area automatically.

```

81 #####
82 #Grid Outputs
83 #####
84 GVar_Rain      =      no
85 GVar_PET       =      no
86 GVar_EPot      =      no
87 GVar_EAct      =      no
88 GVar_W         =      no
89 GVar_SM        =      no
90 GVar_R         =      no
91 GVar_ExcS      =      no
92 GVar_ExcI      =      no
93 GVar_RS       =      no
94 GVar_RI       =      no
95 #####

```

Figure 4-9 Sample Grid Outputs in “ProjectName.Project”

- GVar_Rain: The input precipitation; unit is mm/hour.
- GVar_PET: The input PET; unit is mm/hour.
- GVar_EPOT: **GVar_PET*KE**
- GVar_EAct: The depth of simulated actual evapotranspiration; unit is mm/hour.
- GVar_W: The depth of water filling the pore space bucket "**WM**"
- GVar_SM: Soil Moisture, a percentage of the **WM** and equals **GVar_W/WM**
- GVar_R: The simulated discharge of each grid cell; unit is m³/s.
- GVar_ExcS: The depth of surface excess rain; unit is mm/hour.
- GVar_ExcI: The depth of interflow excess rain; unit is mm/hour.
- GVar_RS: The depth of overland flow; unit is mm/hour.
- GVar_RI: The depth of interflow flow; unit is mm/hour.

4.9 Date Outputs

```

95 #####:
96 NumOfOutputDates = 3 !3
97 OutputDate_1 = 2003010103
98 OutputDate_2 = 2003010106
99 OutputDate_3 = 2003010112
100 #####:
    
```

Figure 4-10 Sample Output Dates in “ProjectName.Project”

Date Outputs is to be specified some dates what user is interested in.

NumOfOutputDates: The Number of Output Date

OutputDate_X: The Xth Date to output, The value of “X” is up to **NumOfOutputDates** (X = [1~ NumOfOutputDates]).

4.10 Number of Lakes

```

105 #####:
106 NumOfLakes = 0
107 #####:
    
```

Figure 4-11 Sample Number Lake in “ProjectName.Project”

NumOfLakes is to be specified the number of Lakes in this research region.

NumOfLakes: The Number of Lakes

5 Inputs & Outputs

CREST v2.1 can read all the Grid file formats (such as "ASBIMO", "BIBIMO", "ASC", "TXT", "DBIF", "BIFFIT", "TRMMRT", "TRMMV6" and "NMQBIN") and can clip the file automatically when this file is not equal to the extent defined in "ProjectName.Project", so user does not need to extract the research area by themselves as long as your prepared input files have broader space domain.

Note: Users can learn how to prepare the data using ArcGIS from the workshop Dr. Xianwu Xue hosted in Kenya, please click this [link](#)¹ to access it.

5.1 Basics Folder

This folder contains the basic file for the model, such as DEM file, FDR file (Flow Direction), FAC file (Flow Accumulation) and so on.

5.1.1 DEM File

Required:

Always

Name:

DEM.*

Format:

All Formats

Purpose:

Contains a digital elevation model of the basin area, with heights in meters

Notes:

¹ http://hydro.ou.edu/files/Crest_Workshops/Kenya_Xianwu_2012/DayTwo/Hands-on%20Session-Preparing%20Data%20For%20CREST%20Model.pdf

The coordinate system of CREST v2.1 can use both Geographic Coordinate System and Projected Coordinate System (PCS)

5.1.2 FDR File

Required:

Always

Name:

FDR.*

Format:

All Formats

Purpose:

Contain a flow direction from each cell to its steepest downslope neighbor of the basin area.

Notes:

The coordinate system of FDR File should be same as DEM File.

In the former version of CREST, direction coding only use the rule like Figure 5-1 (a) generated by “CNT”, however, most popular software (like ArcGIS) use the rule like Figure 5-1 (b), so CREST v2.1 uses both of the two rules.

8	1	2
7		3
6	5	4

(a)

32	64	128
16		1
8	4	2

(b)

Figure 5-1 Flow Direction Coding

5.1.3 FAC File

Required:

Always

Name:

FAC.*

Format:

All Formats

Purpose:

Contains accumulation flow to each cell of the basin area.

Notes:

The coordinate system of FAC File should be same as DEM File.

5.1.4 Mask File

Required:

Optional

If omitted

If **HasOutlet** == “**yes**”, then CREST v2.1 will generate the mask file based on Outlet location.

If **HasOutlet** == “**no**”, then CREST v2.1 will generate the mask file based on NoData_Value in DEM file.

Name:

Mask.*

Format:

All Formats

Purpose:

Contains a mask of the basin, indicating which cells in the other terrain are inside the basin

Notes:

The coordinate system of Mask File should be same as DEM File.

5.1.5 GridArea File

Required:

Optional

If omitted, CREST v2.1 will generate the GridArea file based on the coordinate system.

Name:

GridArea.*

Format:

All Formats

Purpose:

Contain the area of each cell in the basin

Notes:

The coordinate system of GridArea File should be same as DEM File.

5.1.6 AreaFact File

Required:

Optional

If omitted, CREST v2.1 will assign AreaFact.file a uniform value (1.00).

Name:

AreaFact.*

Format:

All Formats

Purpose:

Contains the area of each cell in the basin

Notes:

The coordinate system of AreaFact File should be same as DEM File.

5.1.7 Stream File

Required:

Optional, however if Stream file is omitted, Stream.def must be required.

If omitted, CREST v2.1 will read the threshold to determinate the stream from

Stream.def.

Name:

Stream.*

Format:

All Formats

Purpose:

Contain the information to show whether each cell is the stream.

Notes:

The coordinate system of Stream File should be same as DEM File.

5.1.8 Stream.def File

Required:

Optional, however if **Stream.def** is omitted, Stream file must be required.

Only use when Stream file omitted.

Name:

Stream.def

Format:

ASCII, only contain one value

Purpose:

Contain the threshold for determining the stream.

Notes:

Stream.def is used to compatible with the former version of CREST, instead of **Th** parameter in the former version of CREST.

5.1.9 Slope File

Required:

Optional

If Slope omitted

If **Slope.def** exists, CREST v2.1 will calculate the Slope like the former version.

If **Slope.def** does not exist, CREST v2.1 will calculate the Slope automatically.

Name:

Slope.*

Format:

All Formats

Purpose:

Identify the rate of maximum change in DEM file from each cell.

Notes:

The coordinate system of Slope File should be same as DEM File.

5.1.10 Slope.def File

Required:

Optional

Only use when Slope file omitted, CREST v2.1 will read this file. If **Slope.def** is omitted yet, CREST v2.1 will calculate the Slope automatically.

Name:

Slope.def

Format:

ASCII, only contain one value

Purpose:

Contain the threshold for determining the stream.

Notes:

Slope.def is used to compatible with the former version of CREST, instead of **GM** parameter in the former version of CREST.

5.1.11 Lake Mask File

Required:

Optional

If NumOfLakes==0 then

omitted

Name:

LakeMask.*

Format:

All Formats

Purpose:

Contains a mask of lakes in this region, indicating which cells is the lake

Notes:

The coordinate system of LakeMask File should be same as DEM File.

5.2 Params Folder

This folder contains all the configuration and values of parameters for the model. There are total 18 parameters, classified into four types in this new version (see Table 5-1).

CREST v2.1 puts the initial condition into ICS folder (will introduce later), **TH** and **GM** are optional control parameters, and **AreaFact** can be calculated by ArcGIS or other software, or by CREST v2.1 automatically. So, there are 12 essential parameters in CREST v2.1. The look up tables, the range and the default value of part/all of these parameters are listed in Appendices Table 10-1, Table 10-2 and Table 10-3.

Table 5-1 Classification in CREST v2.1 vs v1.6c

Module	Symbol (v2.1)	Symbol (v1.6c)	Description
Initial condition	W0	iWU	Initial Value of Soil Moisture
	SS0	iSO	Initial value of Overland Reservoir
	SI0	iSI	Initial value of Interflow reservoir
Physical Parameters	Ksat	pFc	the Soil saturate hydraulic conductivity
	RainFact	Rain	the multiplier on the precipitation field
	WM	pWm	The Mean Water Capacity
	B	B	the exponent of the variable infiltration curve
	IM	pIM/100	Impervious area ratio
	KE	pKE	The factor to convert the PET to local actual
Conceptual Parameters	coeM	coeM	overland runoff velocity coefficient
	expM	expM	overland flow speed exponent
	coeR	River	multiplier used to convert overland flow speed to channel flow speed
	coeS	Under	multiplier used to convert overland flow speed to interflow flow speed
	KS	LeakO	Overland reservoir Discharge Parameter
Adjustment Parameters	KI	LeakI	Interflow Reservoir Discharge Parameter
	(Omitted)/TH	TH	Threshold to determine which cells are river cells
	(Omitted)/GM	GM	downstream cell is higher than the upstream downstream cell is a nodata/outside region cell
	AreaFact	AreaC	multiplier that modifies the area of grid cells

5.2.1 Parameters.txt File

Required:

Always

Name:

Parameters.txt

Format:

ASCII

Purpose:

Contain the configuration for all parameters in CREST v2.1

Notes:

The statement in the “Parameters.txt” file can be listed in any order, but the keywords should not be changed. The format of the statement is:

Keyword = Value

Such as:

SymbolType = Uniform/Distributed

If SymbolType = Uniform then

Symbol = Value

Else

Symbol.* file must be provided in the same folder.

End if

The statement appearing on the same line should be space- or tab-separated.

Comment lines must have a pound sign, #, in the first column.

Comment for the statement in the line must be placed after **Value** and be sure to leave at least one space or tab between the **Value** and the Comments.

Keyword is not case sensitive.

5.2.2 “Sysmbol.*” File

Required:

Optional

Only needed when this parameter’s style is **Distributed**.

Name:

ParameterName.*

“ParameterName” possibly likes “Rain”

Format:

ASCII

Purpose:

Contain the configuration for all parameters in CREST v2.1

Notes:

The file coordinate system of Slope File should be same as DEM File.

5.3 State Folder

This folder contains the state files, such as “State_StartDate_SS0.*”, “State_StartDate_SI0.*” and “State_StartDate_W0.*” when **LoadState** = “yes”. When **SaveState** = “yes”, then “State_EndDate_SS0.*”, “State_EndDate_SI0.*” and “State_EndDate_W0.*” will be created after running the model.

5.4 ICS Folder

This folder contains all the configuration and values of initial conditions for the mode.

5.4.1 InitialConditions.txt File

Required:

Always

Name:

InitialConditions.txt

Format:

ASCII

Purpose:

Contain the configuration for initial conditions in CREST v2.1

Notes:

The statement in the “InitialConditions.txt” file can be listed in any order, but the keywords should not be changed. The format of the statement is:

Keyword = Value

Such as:

SymbolType = Uniform/Distributed

If SymbolType = Uniform then

Symbol = Value

Else

Symbol.* file must be provided in the same folder.

End if

The Symbol includes “SS0”, “SI0” and “W0” (see Table 5-1).

The statement appearing on the same line should be space- or tab-separated.

Comment lines must have a pound sign, #, in the first column.

Comment for the statement in the line must be placed after **Value** and be sure to leave at least one space or tab between the **Value** and the Comments.

Keyword is not case sensitive.

5.4.2 “Sysmbol.*” File

Required:

Optional

Only needed when this parameter’s style is **Distributed**.

Name:

ParameterName.*

“ParameterName” possibly likes “Rain”

Format:

ASCII

Purpose:

Contain the configuration for all parameters in CREST v2.1

Notes:

The file coordinate system of Slope File should be same as DEM File.

5.5 OBS Folder

This folder contains all the observed runoff data for the model calibration or verification. The file’s name is name as “OutPixNameX_Obs.csv” and/or “OutletName_Obs.csv” (“.csv” is the comma delimited file). “OutPixNameX” and “OutletName” are the same as the project file.

5.6 Calibs Folder

This folder contains all the configuration and values of calibration for the model.

Note: Users can learn how to calibration the model using ArcGIS from the workshop Dr. Xianwu Xue hosted in Kenya, please click this [link](#)² to access it.

5.6.1 Calibrations.txt File

Required:

Always

Name:

Calibrations.txt

Format:

² http://hydro.ou.edu/files/Crest_Workshops/Kenya_Xianwu_2012/DayTwo/Hands-on%20Session-Calibrate%20the%20CREST%20Model.pdf

ASCII

Purpose:

Contain the configuration for calibrations in CREST v2.1

Notes:

The statement in the “Calibrations.txt” file can be listed in any order, but the keywords should not be changed. The format of the statement is:

Keyword = Value

The statement appearing on the same line should be space- or tab-separated.

Comment lines must have a pound sign, #, in the first column.

Comment for the statement in the line must be placed after **Value** and be sure to leave at least one space or tab between the **Value** and the Comments.

Keyword is not case sensitive.

```

1 #####
2 # CREST Calibrations File (Version more than 2.0)
3 #####
4 iseed          =          -3
5 maxn          =          2000
6 kstop         =           10
7 pcento        =         0.0001
8 ngs           =           2
9 #####
10 NCalibStations =           1
11 IsColRow      =          no   # yes: use Col& Row; No: Lan & Lati
12 #####
13 [Station 1 Begin]
14 Name_1       =          NZoia
15 Value_1      =           1
16 Long_1       =         34.08749
17 Lati_1       =         0.1208334
18 #RainFact_1  = 0.9   0.95   1.2
19 #Ksat_1      = 0.9   0.95   1.2
20 #WM_1        = 0.9   0.95   1.2
21 #B_1         = 0.9   0.95   1.2
22 #IM_1        = 0.9   0.95   1.2
23 #KE_1        = 0.9   0.95   1.2
24 #coeM_1      = 0.9   0.95   1.2
25 #expM_1      = 0.9   0.95   1.2
26 #coeR_1      = 0.9   0.95   1.2
27 #coeS_1      = 0.9   0.95   1.2
28 #KS_1        = 0.9   0.95   1.2 # Min   Value   Max
29 KI_1         = 0.9   0.95   1.2
30 [Station 1 End]

```

Figure 5-2 Sample of “Calibrations.txt” file

1. SCE-UA Parameters

- iseed: Initial random seed;
- maxn: Max no. of trials allowed before optimization is terminated
- kstop: Number of shuffling loops in which the criterion value must change by the given percentage before optimization is terminated
- pcento: Percentage by which the criterion value must change in given number of shuffling loops
- ngs: Number of complexes in the initial population

2. Configuration for calibration

- NCalibStations: Number of Calibrated Stations
- IsColRow: Specified if the location of calibrated station is relative to the basic grids or in latitude and longitude. A value of “yes” means the outlet of the pixels is a column and row, a value of “no” means the outlet

is longitude and latitude.

3. Configuration for Each Station

- Name_X: The name of the **X**th station
- Value_X: The region value of the **X**th station
- Long_X: The longitude of the **X**th station when **IsColRow** is assigned “no”.
- Lati_X: The latitude of the **X**th station when **IsColRow** is assigned “no”.
- Col_X: The Column of the Outlet Pixels when **IsColRow** is assigned “yes”.
- Row_X: The Row of the Outlet Pixels when **IsColRow** is assigned “yes”.
- Label_X: The minimum, initial value and maximum of the **X**th Label parameter for calibration. The label name can see Table 5-1**Error! Reference source not found.**. The format of this statement is:
- | | | | | |
|---------|---|-----|-------|-----|
| Label_X | = | Min | Value | Max |
|---------|---|-----|-------|-----|
- X** is the number of station to calibration.
- Only required when user want to calibrate this parameter.

5.6.2 CalibMask.* File

Required:

Optional

Name:

CalibMask.*

Format:

All Formats

Purpose:

Contain the order number for calibration, when have more than ONE calibrated station. The number depends on the regional number of each station.

Notes:

The coordinate system of **CalibMask** File should be same as DEM File.

5.7 Rains Folder

This folder contains the precipitation data, the format of file in the folder depending on the **RainFormat** specified in the “ProjectName.Project” file. The CREST model can clip the region defined in the “ProjectName.Project” file automatically.

5.8 PETs Folder

This folder contains the potential evaporation data, the format of file in the folder depending on the **PETFormat** specified in the “ProjectName.Project” file; and the CREST v2.1 can clip the region defined in the “ProjectName.Project” file automatically.

5.9 Results Folder

This folder contains the output files, the format of file in the folder depending on the **ResultFormat** specified in the “ProjectName.Project” file.

6 Run Styles

Different run styles have different combinations of outputs; the following section will introduce the outputs for each style.

6.1 Simulation

6.1.1 Running in Simulation Mode

To run the model in simulation mode the run style in the project file must be set to "**simu**". Precipitation data and PET data are also needed for the simulation period. By default CREST reads the "ProjectName.Project" located in the current working directory. However, as of CREST v2.1 it is possible to specify the project file name as a command line option to the CREST executable.

6.1.2 Simulation Mode Standard Outputs

```

F:\XXWCREST_DEV\XXWCVF\CREST_v2.0\Debug\XXWCVF\CREST_v2.exe
Enter the name of the Project FILE:
F:\XXWCREST_DEV\XXWCVF\CREST_v2.0\XXV_MZoIa_Project\MZoIa

CREST
COUPLED ROUTING AND EXCESS STORAGE (OO & NASA)
Version 2.1 10/31/2014

Run start date and time (yyyy/mm/dd hh:mm:ss): 2011/02/07 0:53:43

Reading Project Data!
Reading Basic Data!
Getting Mask Map of Outlet!
Writing Mask Map of Outlet to File!
Getting Mask Map of OutPix Num 1 !
Writing Mask Map of OutPix Num 1 to File!
Getting Mask Map of OutPix Num 2 !
Writing Mask Map of OutPix Num 2 to File!
Reading Parameters' Data!
Reading Initial Conditions Data!

Running Style is Simulation!
1 2003-01-01 00:00:00
2 2003-01-01 03:00:00
3 2003-01-01 06:00:00
4 2003-01-01 09:00:00
5 2003-01-01 12:00:00
6 2003-01-01 15:00:00
7 2003-01-01 18:00:00
8 2003-01-01 21:00:00
9 2003-01-02 00:00:00

The results of the Outlet is:
NSCE: 0.99999999
Bias(C): 0.00272328
CC: 1.00000000

Run end date and time (yyyy/mm/dd hh:mm:ss): 2011/02/07 0:53:44
Elapsed run time: 1.128 Seconds

Press any key to continue!

```

Figure 6-1 Output results in screen for Simulation mode

The 1 line is the comment for requiring user to enter the name of the project file.

The 2 line is the user-typed line for the name and path of the project file.

The 3 line is the separation line.

The 4~6 line is the information of the CREST v2.1.

The 7 line is the separation line.

The 8 line is the start date and time for running the model.

The 9 line is the separation line.

The 10~21 line is the reading and writing data.

The 22 line is the separation line.

The 23 line is the information for running style to the current running model.

The 24~32 line is the reading and writing data.

The 33 line is the separation line.

The 34~37 line is the output results.

The 38 line is the separation line.

The 39 line is the end date and time for running the model.

The 40 line is the elapsed run time for running the model.

6.1.3 Simulation Mode File Outputs

Besides output the results to the screen, CREST v2.1 also outputs the results to a log file in the same folder as project file, named as “ProjectName_YYYY.MM.DD-HH.UU.SS_CREEST.log”, for example: “NZoia_2011.02.07-00.33.05_CREEST.log”. The time in this file’s name depending on the date and time the model is running. The log file will help the user record all the things the user wants to see, even on the Linux operating system.

There are many files to output when the model is running in the simulation mode:

Mask.*: When the mask file is omitted in the basics folder.

Slope.*: When the slope file is omitted in the basics folder.

Outlet_OutletName_Mask.*: The mask file for the specified outlet.

Outlet_OutletName_Results.csv: The results for the outlet location (Table 6-1).
(Regional Mean Value based on the **Outlet_OutletName_Mask.***)

Table 6-1 Sample of Outlet_OutletName_Results.csv

DateTime	Rain	PET	EPot	EAct	W	SM	RS	RI	ExcS	ExcI	R	RObs
2003/1/1 0:00	0	0.215	0.043	0.023	38.451	0.534	1.114	1.452	0	0	0.605	0.605
2003/1/1 3:00	0	0.215	0.043	0.023	38.382	0.533	1.112	1.452	0	0	2.359	2.359
2003/1/1 6:00	0.009	0.215	0.043	0.024	38.331	0.533	1.107	1.452	0	0.002	3.375	3.375
2003/1/1 9:00	0	0.215	0.043	0.023	38.263	0.532	1.1	1.452	0	0	4.655	4.655
2003/1/1 12:00	0	0.215	0.043	0.023	38.194	0.531	1.089	1.452	0	0	6.218	6.218
2003/1/1 15:00	0.889	0.215	0.043	0.03	39.705	0.552	1.15	1.508	0.131	0.225	7.681	7.681
2003/1/1 18:00	0.018	0.215	0.043	0.025	39.668	0.551	1.137	1.509	0.001	0.004	8.794	8.794
2003/1/1 21:00	0	0.215	0.043	0.024	39.597	0.55	1.122	1.508	0	0	9.526	9.526
2003/1/2 0:00	0	0.215	0.043	0.024	39.526	0.549	1.108	1.508	0	0	10.018	10.018

Outlet_OutletName_Results_Statistics.csv: The statistics for outlet location.

Table 6-2 Sample of Outlet_OutletName_Results_Statistics.csv

NSCE	1
Bias (%)	2.72E-03
CC	1

OutPix_OutPixName_X_Mask.*: The mask file for the specified output pixel.

OutPix_OutPixName_X_Results.csv: The results for the output pixel location.
(Regional Mean Value based on the
Outlet_OutPixName_X_Mask.*)

OutPix_OutPixName_X_Results_Statistics.csv: The statistics for outlet location
(Table 6-2).

6.2 Automatic Calibration using SCE-UA

6.2.1 Running in Automatic Calibration Mode using SCE-UA

To run the model in automatic calibration mode using SCE-UA, the run style in the project file must be set to "**cali_SCEUA**". Precipitation data, PET data and observed discharge are all needed for the calibration period. A special feature such as Reinitializing or Resuming Calibration has been included in CREST v2.1.

6.2.2 Automatic Calibration Mode Standard Output using SCE-UA

```

F:\XXWCREST_DEV\XXWCVCFCREST_v2.0\Debug\XXWCVCFCREST_v2.exe
Enter the name of the Project FILE:
F:\XXWCREST_DEV\XXWCVCFCREST_v2.0\XXW_NZoia_Project\Nzoia

                                CREST
                        COUPLED ROUTING AND EXCESS STORAGE <OU & NASA>
                                Version 2.1 10/31/2014

Run start date and time <yyyy/mm/dd hh:mm:ss>: 2011/02/07  1:47:37

Reading Project Data!
Reading Basic Data!
Getting Mask Map of Outlet!
Writing Mask Map of Outlet to File!
Getting Mask Map of OutPix Nun  1 !
Writing Mask Map of OutPix Nun  1 to File!
Getting Mask Map of OutPix Nun  2 !
Writing Mask Map of OutPix Nun  2 to File!
Reading Parameters' Data!
Reading Initial Conditions Data!
Reading calibration's Data!

Running Style is Calibration using SCE-UA!

                                ENTER THE MAIN PROGRAM SCE-UA
@ SCE-UA Run Number              1      Random Seed Value      -3
                                ENTER THE SCEUA SUBROUTINE

*** Evolution Loop Number      0
0.997081081601042  Region Number:  1
0.992378558295108  Region Number:  1
0.980011811683949  Region Number:  1
0.984712997049170  Region Number:  1
0.972207281588515  Region Number:  1
0.992248780045417  Region Number:  1
*** Evolution Loop Number      1
0.999998008224424  Region Number:  1
0.997100589180413  Region Number:  1
0.992920202499234  Region Number:  1
0.999964497861051  Region Number:  1
0.999999977535104  Region Number:  1
0.999999992547714  Region Number:  1
  1  2003-01-01 00:00:00
  2  2003-01-01 03:00:00
  3  2003-01-01 06:00:00
  4  2003-01-01 09:00:00
  5  2003-01-01 12:00:00
  6  2003-01-01 15:00:00
  7  2003-01-01 18:00:00
  8  2003-01-01 21:00:00
  9  2003-01-02 00:00:00

The results of the Outlet is:
NSCE:      0.99999999
Bias(%):   0.00030651
CC:       1.00000000

Run end date and time <yyyy/mm/dd hh:mm:ss>: 2011/02/07  1:48:27
Elapsed run time: 50.783 Seconds

Press any key to continue!

```

Figure 6-2 Output results in screen for cali_SCEUA mode

The 1 line is the comment for requiring user to enter the name of the project file.

The 2 line is the user-typed line for the name and path of the project file.

The 3 line is the separation line.

The 4~6 line is the information of the CREST v2.1.

The 7 line is the separation line.

The 8 line is the start date and time for running the model.

The 9 line is the separation line.

The 10~21 line is the reading and writing data.

The 22 line is the separation line.

The 23 line is the information for running style to the current running model.

The 24~32 line is the reading and writing data.

The 33 line is the separation line.

The 34~36 line is the parameters information for SCE-UA method.

The 37 line is the separation line.

The 38~51 line is the output results for each loop of SCE-UA method.

The 52~65 line is the output results simulated using the calibrated parameters.

The 66 line is the separation line.

The 67 line is the end date and time for running the model.

The 68 line is the elapsed run time for running the model.

6.2.3 Automatic Calibration Mode File Output using SCE-UA

Besides output the results to the screen, CREST v2.1 also outputs the results to a log file in the same folder as project file, named as “ProjectName_YYYY.MM.DD-HH.MM.SS_CREST.log”, for example: “NZoia_2011.02.07-00.33.05_CREST.log”. The time in this file’s name depending on the date and time the model ran. The log file will help the user record all the things the user wants to see, even on the Linux operating system.

There are many files to output when the model is running in the “cali_SCEUA” mode:

Mask.*: When the mask file is omitted in the basics folder.

Slope.*: When the slope file is omitted in the basics folder.

Outlet_OutletName_Mask.*: The mask file for the specified outlet.

Outlet_OutletName_Results.csv: The results for the outlet location (Table 6-1).
(Regional Mean Value based on the
Outlet_OutletName_Mask.*)

Outlet_OutletName_Results_Statistics.csv: The statistics for outlet location.

OutPix_OutPixName_X_Mask.*: The mask file for the specified output pixel.

OutPix_OutPixName_X_Results.csv: The results for the output pixel location.
(Regional Mean Value based on the
Outlet_OutPixName_X_Mask.*)

OutPix_OutPixName_X_Results_Statistics.csv: The statistics for outlet location.

SCEUAOut_YYYY.MM.DD-HH.UU.SS.dat: The results for SCE-UA method

Label.*: The calibrated parameters file. **Labels** shows in Table 5-1.

6.3 Simulation in real time mode

6.3.1 Running in Real Time Mode

To run the model in real time mode, the run style in the project file must be set to "**RealTime**". Precipitation data and PET data are needed for the real time period.

6.3.2 Real Time Mode Standard Output

It is the same as Simulation mode, however, the end date and time depending on the latest available precipitation and PET data or images.

6.3.3 Real Time Mode File Output

It is the same as Simulation, however, the end date and time is up to the available precipitation and PET.

6.4 Return Period mode

6.4.1 Running in “repe” Mode

To run the model in “**repe**” (Return Period) mode, the run style in the project file must be set to "**repe**". It needs run the model in “**simu**” mode with **GOVar_R=“yes”** in advance, and then run the model in “**repe**” mode.

6.4.2 Real Time Mode Standard Output

```

F:\XXWCREST_DEV\XXWCVFCREST_v2.0\Debug\XXWCVFCREST_v2.exe
Enter the name of the Project FILE:
F:\XXWCREST_DEV\XXWCVFCREST_v2.0\XXW_NZoia_Project\NZoia

                                CREST
                   COUPLED ROUTING AND EXCESS STORAGE <OU & NASA>
                                Version 2.1 10/31/2014

Run start date and time <yyyy/mm/dd hh:mm:ss>: 2011/02/07 11:06:25

Reading Project Data!
Reading Basic Data!
Getting Mask Map of Outlet!
Writing Mask Map of Outlet to File!
Getting Mask Map of OutPix Num 1 ?
Writing Mask Map of OutPix Num 1 to File!
Getting Mask Map of OutPix Num 2 ?
Writing Mask Map of OutPix Num 2 to File!
Reading Prarmeters' Data!
Reading Initial Conditions Data!

Running Style is Return Period!
Loading Runoff File: 2003010100
Loading Runoff File: 2003010103
Loading Runoff File: 2003010106
Loading Runoff File: 2003010109
Loading Runoff File: 2003010112
Loading Runoff File: 2003123115
Loading Runoff File: 2003123118
Loading Runoff File: 2003123121
Sorting for Return Period!
Exporting Num      1

Run end date and time <yyyy/mm/dd hh:mm:ss>: 2011/02/07 11:09:25
Elapsed run time: 3 Minutes, 0.027 Seconds

Press any key to continue!

```

Figure 6-3 Output results in screen for Return Period mode

The 1 line is the comment for requiring user to enter the name of the project file.

The 2 line is the user-typed line for the name and path of the project file.

The 3 line is the separation line.

The 4~6 line is the information of the CREST v2.1.

The 7 line is the separation line.

The 8 line is the start date and time for running the model.

The 9 line is the separation line.

The 10~19 line is the reading and writing data.

The 20 line is the separation line.

The 21 line is the information for running style to the current running model.

The 22~29 line is reading runoff data.

The 30 line is sorting for return period.

The 31 line is exporting file Num 1.

The 32 line is the separation line.

The 33 line is the end date and time for running the model.

The 34 line is the elapsed run time for running the model.

6.4.3 Return Period Mode File Output

Besides output the results to the screen, CREST v2.1 also outputs the results to a log file in the same folder as project file, named as “ProjectName_YYYY.MM.DD-HH.MM.SS_CREAST.log”, for example: “NZoia_2011.02.07-00.33.05_CREAST.log”. The time in this file’s name depending on the date and time the model ran. The log file will help the user record all the things the user wants to see, even on the Linux operating system.

There is only one types of file to output when the model is running in the “**repe**” mode:

Level.X.*: **X** is the level number, recording the return period values.

7 Implementation of the CREST model for other basins

The CREST model automatically runs over the region defined by the project file. Therefore, if you are operating with global basic grids it is possible to easily and quickly model a basin in the world by just simply defining the outlet of a new basin. In the event that the basic grids you are using do not cover the region which you want to model or if you want to model a region with a finer resolution then it is necessary to derive new project file. The steps to do this are described below.

Fully implementing the CREST model on any basin can be achieved in a three-step process:

1. A project file for the new modeling region needs to be created.
 - a. Copy an existing project file (even one of the provided example project files) and modify the paths to point to the location of the new paths of the folders.
 - b. Determine the latitudes and longitudes of a rectangle around the region which you wish to model. These do not have to be precise by any means and can be pulled from Google Earth or Google Maps for an approximate region around the basin you wish to model. However, **the basin you wish the model on must be entirely contained in the bounding rectangle you specified.**
 - c. In order for CREST to work with the DEM, FDR and FAC files produced by the CNT Tool or other software, they must be named **DEM.***, **FDR.*** and **FAC.***.
2. The model can now be run for your new basin in any desired modes. To get realistic results it is necessary to generate *a priori* parameters from available land surface datasets or later calibrate the model using a gauged station within your defined new basin. The automatic calibration built into the

CREST model is the easiest way to calibrate the model.

8 Contact

Development and maintenance of the current official version of the OU-NASA CREST model is conducted at the University of Oklahoma, Hydrometeorology and Remote Sensing Laboratory (<http://hydro.ou.edu>) and Advanced Radar Research Center (ARRC) located in the National Weather Center (<http://nwc.ou.edu>). For information about the current release and future development plan of the CREST model family, please visit the page (<http://hydro.ou.edu/research/crest/>), or send e-mail to Dr. Yang Hong (yanghong@ou.edu) and Dr. Xianwu Xue (xuexianwu@ou.edu).

9 Selected CREST model Related References

- Wang, J., Y. Hong, L. Li, J.J. Gourley, K. Yilmaz, S. I. Khan, F.S. Policelli, R.F. Adler, S. Habib, D. Irwin, S.A. Limaye, T. Korme, and L. Okello, 2011: The Coupled Routing and Excess Storage (CREST) distributed hydrological model. *Hydrological Sciences Journal*, **56**, 84-98.
- Xue X, Hong Y, Limaye AS, Gourley JJ, Huffman GJ, Khan SI, et al., 2013: Statistical and hydrological evaluation of TRMM-based Multi-satellite Precipitation Analysis over the Wangchu Basin of Bhutan: Are the latest satellite precipitation products 3B42V7 ready for use in ungauged basins? *Journal of Hydrology*, 499(0): 91-99.
- Khan, S. I., Y. Hong, J. Wang, K.K. Yilmaz, J.J. Gourley, R.F. Adler, G.R. Brakenridge, F. Policelli, S. Habib, and D. Irwin, 2011: Satellite Remote Sensing and Hydrologic Modeling for Flood Inundation Mapping in Lake Victoria Basin: Implications for Hydrologic Prediction in Ungauged Basins, *IEEE Transactions on Geosciences and Remote Sensing*, 49(1), 85-95, Jan. 2011, doi:

10.1109/TGRS.2010.2057513

Wu H, Adler RF, Hong Y, Tian Y, Policelli F., 2012: Evaluation of Global Flood Detection Using Satellite-Based Rainfall and a Hydrologic Model. *Journal of Hydrometeorology*, 13(4): 1268-1284.

10 Appendix A Look-up Tables

Table 10-1 Look-up Table for UMD Vegetation Types

Value	UMD Vegetation Category	Rooting Depth (m)
0	Water	0.001
1	Evergreen Needleleaf Forest	1
2	Evergreen Broadleaf Forest	1.25
3	Deciduous Needleleaf Forest	1
4	Deciduous Broadleaf Forest	1.25
5	Mixed Forest	1.125
6	Woodland	0.997
7	Wooded Grassland	0.872
8	Closed Shrubland	0.651
9	Open Shrubland	0.578
10	Grassland	0.75
11	Cropland	0.75
12	Bare Ground	0.55
13	Urban and Built	0.797

Table 10-2 Look-up Table for HWSD Soil Texture

Code	Texture	Abbr.	Fild Capacity $\theta_{fc}(m^3/m^3)$	Permanent Wilting Point θ_{pw} (m^3/m^3)	Hydraulic conductivity K_{sat} (cm/h)
0	No_Soil	NS	0	0	0.00001
1	Clay(heavy)	CH	0.36	0.21	0.03
2	Silty Clay	SIC	0.36	0.21	0.05
3	Clay	C	0.36	0.21	0.075
4	Silty Clay Loam	SICL	0.34	0.19	0.1
5	Clay Loam	CL	0.34	0.21	0.1
6	Silt	SI	0.32	0.165	0.495
7	Silt Loam	SIL	0.3	0.15	0.65
8	Sandy Clay	SC	0.31	0.23	0.15
9	Loam	L	0.26	0.12	0.34
10	Sandy Clay Loam	SCL	0.33	0.175	0.15
11	Sandy Loam	SL	0.23	0.1	1.09
12	Loamy Sand	LS	0.14	0.06	2.99
13	Sand	S	0.12	0.04	11.78

Table 10-3 Range and Default value of Each Parameter

Params	Min	Default	Max
RainFact (l)	0.5	1.0	1.2
Ksat (mm/d)	0	500	1000
WM(mm)	80	120	200
B (l)	0.05	0.25	1.5
IM (l)	0	0.05	0.2
KE (l)	0.1	0.95	1.5
coeM	1	90	150
expM (l)	0.1	0.5	2
coeR (l)	1	2	3
coeS (l)	0.001	0.3	1
KS (l)	0	0.6	1
KI (l)	0	0.25	1